

**SPACER RINGS ADDED BETWEEN THE WHEEL HUB BEARINGS IN HUB REDUCTION REAR AXLES**

**Change:** A spacer ring and adjusting shim(s) have been added in the wheel hub assembly in the hub reduction rear axles. This change has been made to reduce the need for re-tightening the wheel hub bearings.

**Identify:** The part number of the complete axle will remain the same. There are no changes in other parts in the axle, only the spacer rings and the adjusting shims have been added.

**Date of change:**

<b>Axle product code</b>	<b>Serial No.</b>	<b>Date</b>
009/FRDP-13-S-0468/003	93234	5.10.1999
009/FRMP-13-S-0409/003	93249	5.10.1999
009/FRDP-13-S-0409/005	93248	5.10.1999
012/SRDP-30-S-1641/002	93320	12.10.1999
012/SRDP-30-S-2057/006	93367	12.10.1999
059/FRMP-13-S-0556/001	93330	14.10.1999
059/FRDP-13-S-0556/001	93323	14.10.1999

All other FRDP-11, FRDP-12, FRDP-13, FRDP-14, FRDP-16, FRMP-11, FRMP-12, FRMP-13, FRMP-14, FRMP-16 & SRDP-30-S axles from serial No. 93833, date 3.11.1999. SRDP-30-W (Wet Disc Brake Axles) from serial No. 01383, 31.5.2000.

**Interchangeability:** It is possible to install the new spacer rings and adjusting shims to the earlier design if desired. From the axle serial numbers listed in the table below, the installing of the spacer rings and the adjusting shims can be done without any other changes in the axle. In the axles with the earlier design of hub nut locking (made earlier than the axles in the list), the hub nut, the locking plate and the ring gear hub have to be replaced also according to the Service Bulletins S7001 (SRDP) and S8001 (FRDP & FRMP).

<b>Axle</b>	<b>Serial No.</b>	<b>Date.</b>
FRDP & FRMP-13/16	80191	2/98
SRDP-30-S	72067	9/97
SRDP-30-W	71546	6/97

**Changed parts:**

Description	New Part No.	Qty/axle	Note
Spacer ring, l=29 mm	543-416-0310	2	FRDP & FRMP axles with separate aluminum or cast iron hub cover
Spacer ring, l=44 mm	543-416-0400	2	All SRDP axles and FRDP & FRMP axles with compact hub reduction design
Adjusting shim s=0.10 mm	590731-09510	as reqd.	
Adjusting shim s=0.15 mm	590731-09515	as reqd.	
Adjusting shim s=0.20 mm	590731-09520	as reqd.	
Adjusting shim s=0.50 mm	590731-09550	as reqd.	

**Picture 1. Hub bearings with spacer rings**

1. Spacer ring
2. Shims
3. Locking plate (143-418-0510)
4. Hub nut (599-290-8004)
5. Ring gear hub

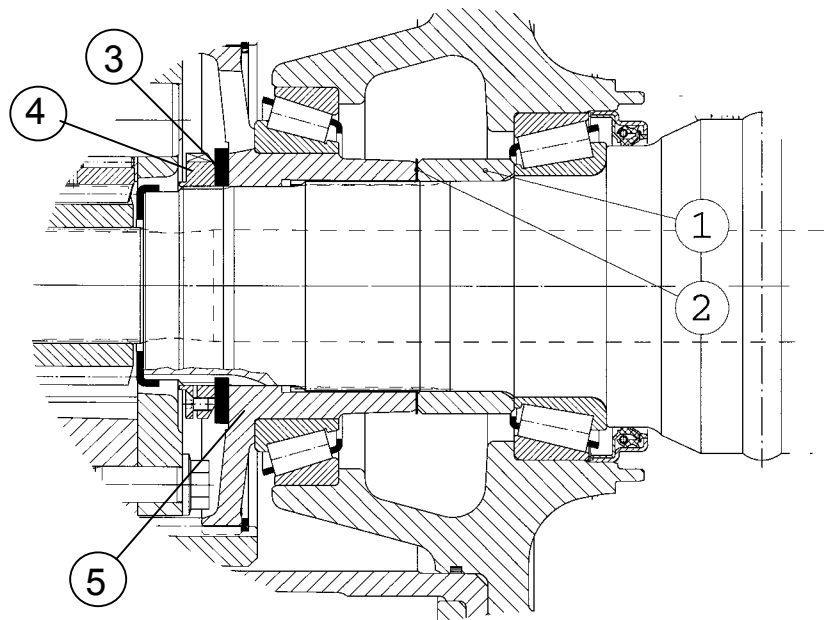

**Adjustment of the wheel hub bearings with spacer rings:**

1. Check the bearing clearance/preload with a dial indicator. Attach the dial indicator by its magnetic holder to the hub and place the tip of the gauge against the ring gear hub. Move the hub in the direction of the axle while turning it back and forth and read the clearance on the dial.
2. If the clearance is over 0.05 mm, [0.002 inches] remove the wheel bearing adjusting nut and remove the ring gear hub with the outer hub bearing inner race. Remove the adjusting shims to reduce the thickness of the shims so that the correct installing preload/clearance from -0.05 to +0.03 mm [-0.002 to 0.001 inches] can be achieved.
3. When adding the spacer rings and the adjusting shims to the earlier design use standard spacer ring (1 in Picture 1) +1,2 mm thick shims (2 in picture 1).
4. Install the hub and bearings as well the ring gear with the ring gear hub.

5. Install the hub nut locking plate and the hub nut.
6. Tighten the hub nut to 250 Nm [185 lb.-ft.] torque while rotating the hub.
7. If the hub rotation stops while torquing the nut, remove the wheel bearing adjusting nut and remove the ring gear hub with the outer hub bearing inner race and insert some additional shim(s).
8. Repeat working phases 4 thru 6 until the wheel hub rotates freely.
9. Tighten the wheel bearing adjusting nut to 1000 Nm [738 lb.-ft.] torque while rotating the hub.
10. Check the wheel hub rolling torque. It must be  $8 \pm 2$  Nm [4.4 - 7.4 lb.] when measured by a torque wrench in the middle of the wheel hub cover (a special fixture is required). If the rolling torque is not correct, add or remove shims as required.

The rolling torque measurement can be done also by a spring scale and a piece of the string around the wheel hub circumference (43 - 71 N [9.7 - 16.0 lb.], Picture 2.) or from the wheel bolt circumference (34 - 56 N [7.6 - 12.6 lb.], Picture 3.).

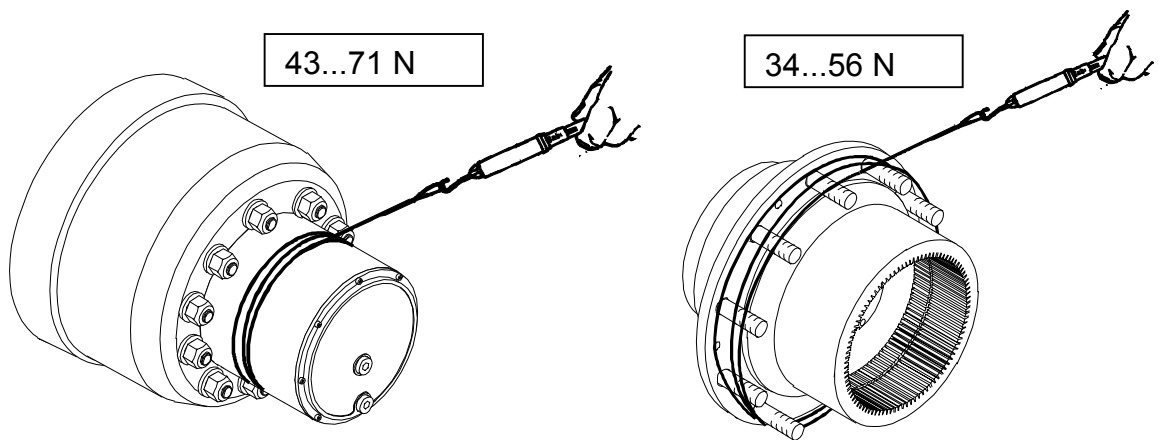

Picture 2. Rolling torque measurement with a spring scale from the wheel hub circumference.

Picture 3. Rolling torque measurement with a spring scale from the wheel bolt circumference.

**Note! This measurement shall be taken with rotating hub.**