

R-22

Rigid Rear Drive Axle

Rear drive axle designed specifically for direct matching with Marmon-Herrington front drive axle MT-22 series.

Marmon-Herrington

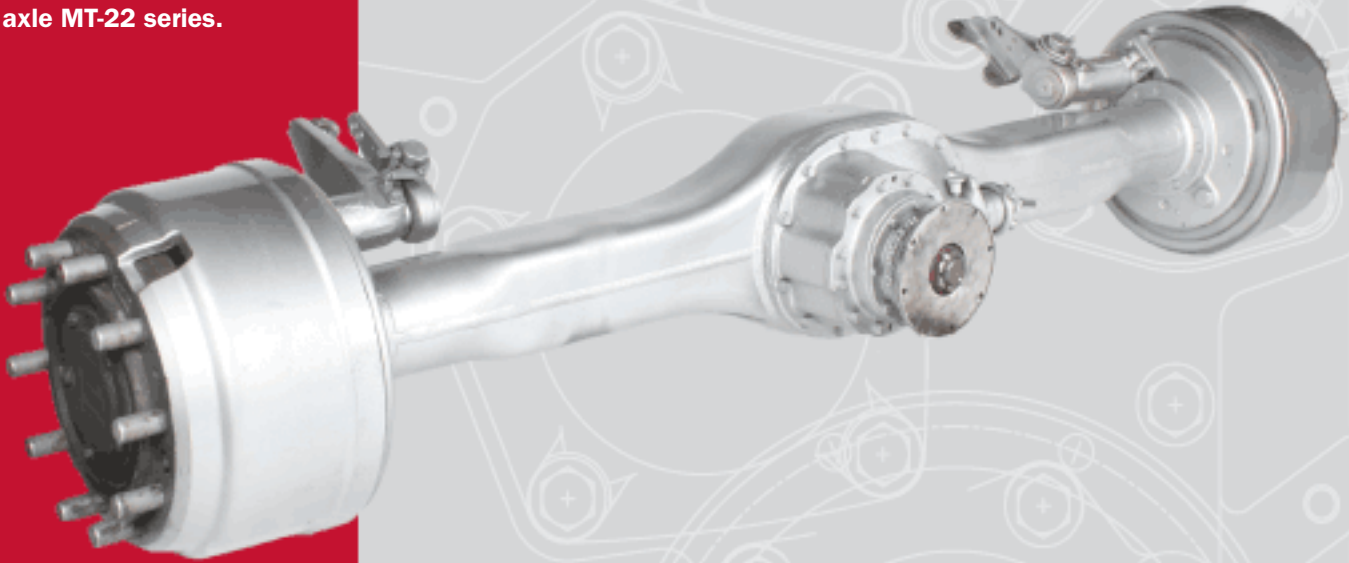

Capacity (at ground): 23,000#*

Reductions Available: 4.25, 4.56, 4.92, 5.29, 5.38, 5.65, 5.83, 6.11, 6.27, 6.68, 7.14, 7.72, 8.36, 8.52

Planetary Hub Reduction: 3.461:1

Axle Type: Full-Floating Driving Rear Axle

Pinion Joint Series: Spicer 1610, 1710, 1760, or 1810 / Meritor 161, 171, 176, or 181 / SPL

Differential: Conventional with Driver-Controlled Lock

Axle Housing: Steel Forging, 20.2 inch³S.M. @ Pad

Wheel Mount: 335MM B.C., 10-Stud with M-22 Thread

Wheel Mounting Distance: 95"

Track: Approximately 81"

Axle Mounting: Spring Centers and Pad Width to Vehicle Requirements

Approximate Axle Weight: 1,650#

Service Brakes: 16 1/2" x 7" Air, S-Cam Actuated, Type 30 Chambers

Parking Brake: Type 30 Spring-Loaded on Service Chamber

* (All applications must be approved by Marmon-Herrington Engineering)

Driving power since 1931.

R-22

Rigid Rear Drive Axle

Marmon-Herrington

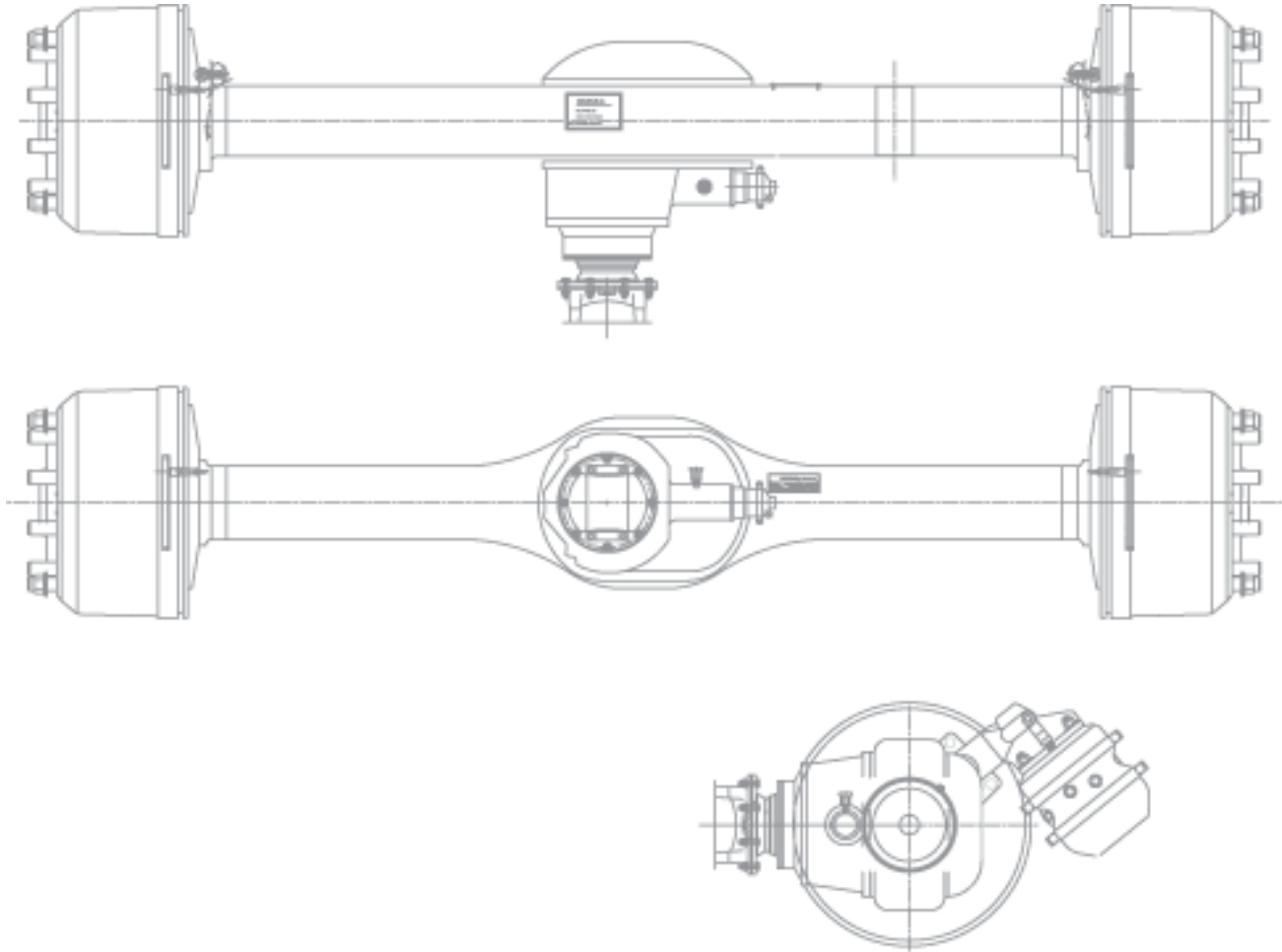

** For dimensional information, please contact Marmon-Herrington.*

Marmon-Herrington:

**A legacy of
engineering
excellence that
lives on today.**

For over 75 years, Marmon-Herrington has been pioneering driving solutions that keep fleets moving and provide long-term value. Among our inventions: the Marmon Wasp, the first car ever to win the Indianapolis 500; double-cardan steering joints and low-profile differentials. Today, we're known for our full line of dependable axle systems

with premium components, product flexibility and best-in-class support.

Whether you're an OEM ready to outfit a fleet or a fleet manager looking for a kitting solution, Marmon-Herrington has the right system to get the job done and keep you moving. To learn more, call us at (800) 227-0727.

